

TECHNICAL SPECIFICATIONS

Nominal diameter	300 mm. 12 in.
Rated impedance	8 ohms
Power capacity	400 w AES
Program power	800 w
Sensitivity	97 dB 2.83v @ 1m @ 2p
Frequency range	35 - 4000 Hz
Recom. enclosure vol.	20 / 70 l 0.7 / 2.6 ft. ³
Voice coil diameter	77 mm. 3 in.
Magnetic assembly weight	6.3 kg. 13.9 lb.
BL factor	18.4 N / A
Moving mass	0.062 kg.
Voice coil length	20 mm
Air gap height	8 mm
X damage (peak to peak)	28 mm

MOUNTING INFORMATION

Overall diameter	312 mm. 12.3 in.
Bolt circle diameter	294.5 mm. 11.6 in.
Baffle cutout diameter:	
- Front mount	277.5 mm. 10.9 in.
- Rear mount	280 mm. 11 in.
Depth	139 mm. 5.47 in.
Volume displaced by driver	4 l 0.14 ft. ³
Net weight	7.1 kg. 15.6 lb.
Shipping weight	7.8 kg. 17.2 lb.

THIELE-SMALL PARAMETERS

Resonant frequency, fs	44 Hz
D.C. Voice coil resistance, Re	6 ohms.
Mechanical Quality Factor, Qms	11.6
Electrical Quality Factor, Qes	0.3
Total Quality Factor, Qts	0.3
Equivalent Air Volume to Cms, Vas	81 l
Mechanical Compliance, Cms	206 mm / N
Mechanical Resistance, Rms	1.5 kg / s
Efficiency, ho (%)	2.3
Effective Surface Area, Sd (m ²)	0.0530 m ²
Maximum Displacement, Xmax	6 mm
Displacement Volume, Vd	316 cm ³
Voice Coil Inductance, Le @ 1 kHz	2.1 mH

DIMENSION DRAWINGS

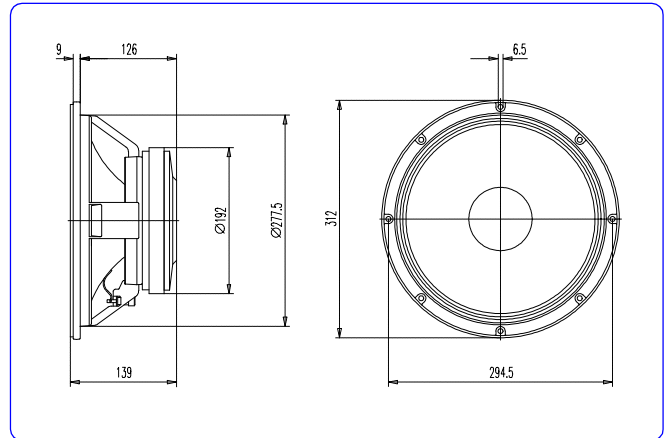

MATERIALS

- **Voice coil:** edgewound copper wire with high temperature bonding strength. Polyimide fiber glass former able to withstand high temperatures.
- **Cone:** paper cone capable to endure the most extreme conditions.
- **Surround:** treated cloth to assure good retaining of elasticity in despite of continuing use.
- **Spider:** treated cotton fibres.
- **Metal parts:** anti-corrosion coated back plate designed to resist aggressive environmental conditions
- **Basket:** specially designed die cast aluminium basket to avoid disturbing resonances.
- **Magnet:** high Curie temperature ferrite.



acústica beyma, s.a.

KEY FEATURES

- High power handling (400 W_{AES})
- 3" edgewound copper voice coil with polyimide fiber glass former
- Optimum winding length for increased linear excursion
- Designed for woofer applications



GENERAL DESCRIPTION

This low frequency transducer is specially intended for the most demanding applications. Its design concept arises from the need of achieve a more resistant loudspeaker that matches the more and more power given by ultimate amplification systems. In order to accomplish that, almost every component of the speaker has been reconsidered: its voice coil has the benefits of an improved manufacturing process, made with the highest quality materials and the diaphragm has been carefully developed to give an extremely flat, smooth response. These characteristics make its integration in compact systems covering the low frequency range a straightforward task.

Moreover, its parameters has been optimized to obtain an excellent bass response when used in small bass-reflex cabinets.

FREQUENCY RESPONSE AND DISTORTION CURVES

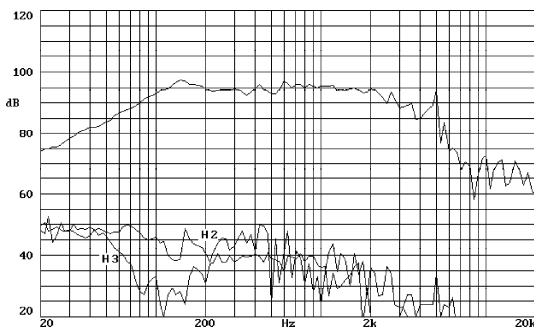

Note: on axis frequency response measured with loudspeaker standing on infinite baffle in anechoic chamber, 1w @ 1m.

FREE AIR IMPEDANCE CURVE

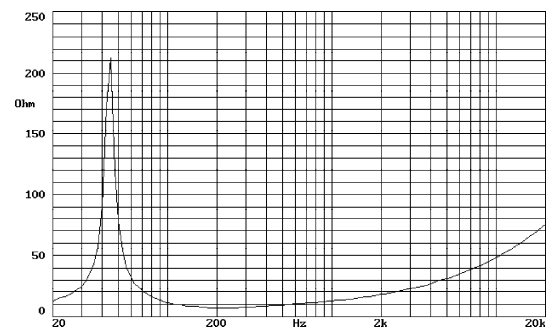

PREDICTED LOW FREQUENCY RESPONSE

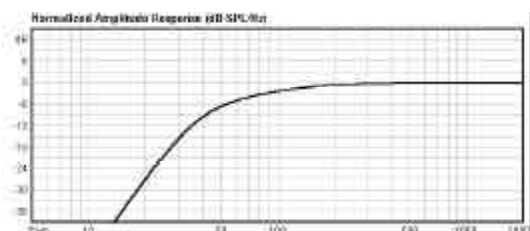

Note: Bass-reflex cabinet, Vb=40 l, fb=40 Hz

POWER COMPRESSION LOSSES

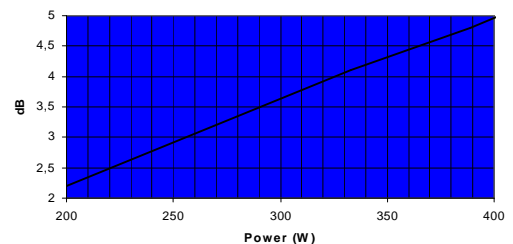

Note: These losses are calculated from a two hours AES power test applying band limited pink noise (25-1200 Hz). The loudspeaker is free-air standing.